



Product Description

The NDI-225-22 is a 225 kV, water cooled stationary anode metal ceramic X-ray source. This source is specifically designed for Non-Destructive Imaging Applications.

X-Ray Tube Specifications

Maximum Peak Voltage	225 kV
Focal Spot EN12543	
Small	D = 1.0 mm
Large	D = 5.5 mm
Focal Spot IEC	
Small	0.4 mm
Large	3.0 mm
Maximum Continuous Rating	
Small	640 W with 4 Litre/min cooling flow
Large	3000 W with 4 Litre/min cooling flow
Target Angle	20°
Cooling Medium	Water
Reference Axis	Perpendicular to port face.
Radiation Coverage	40°
Loading Factors for Leakage Radiation	225 kV, 13 mA
X-Ray Tube Assembly Permanent Filtration	0.8 mm Be
High Voltage Cable	R24
Weight (approx.)	10.5 kg (23.1 lbs)

Instructions for Installation

Connection of the x-ray tube

The careful adjustment of the pressure gap and the use of the correct amount of silicone grease are extremely important. First, clean the rubber cone carefully with a lint-free cloth. Take specific care that the contacts are absolutely free of old grease or oxide layers. Use only pure alcohol for cleaning, no other detergents. Cover the entire cone with a thin film of the supplied silicone grease, apply a rope of approximately 3 cm of grease and spread it gently, avoiding the contact tip. The grease layer must be kept free of air bubbles, dust or dirt.

Cable terminal with mounting flange

Rotate the mounting flange until there is a gap of 3-4 mm between the mounting flange and the tube. Remove the cable plug and carefully grease using the supplied high voltage insulating compound. Introduce the greased terminal plug parallel to the axis of the high voltage receptacle socket and advance until it stops.

Mounting flange

Attach the mounting flange to the tube housing using the flange fastening screws making sure not to rotate the mounting flange from its setup position.

Operation

General

The control of the high voltage and the filament current as well as the design of the cooling unit is the responsibility of the equipment manufacturer.

High Voltage Connection

One terminal type R24 high voltage cables supply high voltage and filament current.

Two different methods of mounting the high voltage cable are available.

Cooling of the Anode

It is the responsibility of the customer to ensure that the cooling medium flow meets the required cooling conditions. Insufficient cooling of the anode can lead to the destruction of the anode, therefore cooling must be switched on before the application of high voltage.

Control of Cooling Medium

Flow, pressure, and temperature of the cooling medium at the inlet to the tube or the tube assembly must be appropriately monitored. High voltage must be terminated when the pressure or flow rate fall below the minimum level or when the temperature exceeds the maximum level. When the tube is switched off the coolant flow must continue for at least 2 minutes in order to protect the anode from destruction.

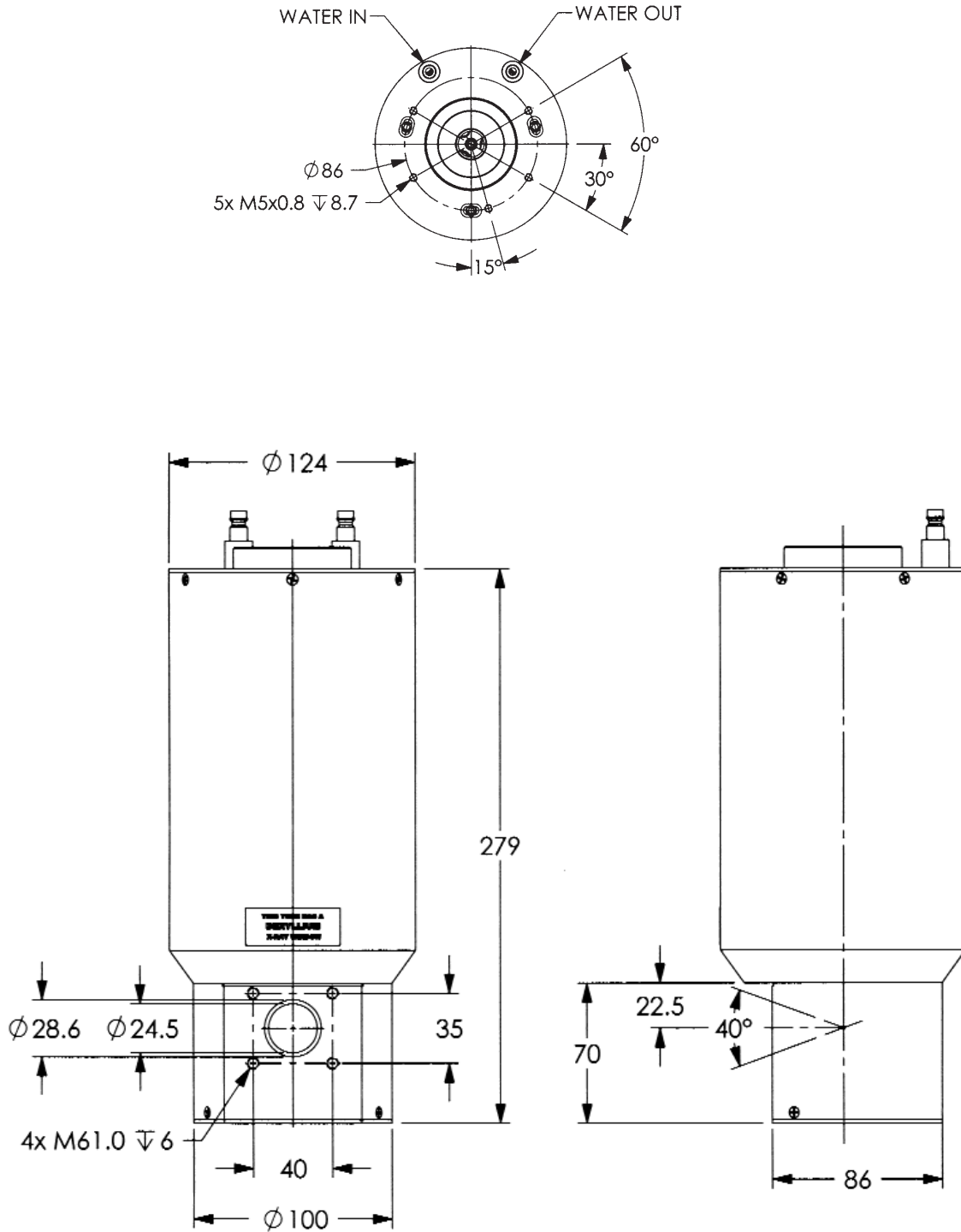

640 Watts

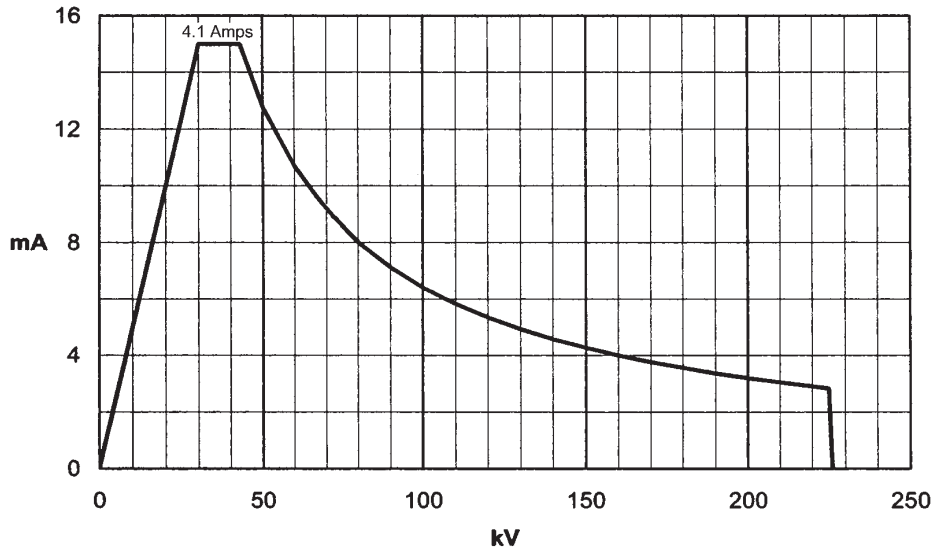

3000 Watts

