

■ Large - Black  
Grand - Noir  
Gross - Schwarz  
Largo - Negro

■ Small - White  
Petit - Blanc  
Klein - Weiss  
Pequeño - Blanco

⏻ Stand - By  
Attente  
Bereitschaft  
En Espera

⏚ Frame or Chassis  
Masse  
Chassis  
Soporte o Chasis

⊙ X-Ray Tube  
Tube Radiogène  
Röntgenröhre  
Tubo de Rayos X

⚡ Radiation Filter or Filtration  
Filtre de rayonnement  
Filterung  
Filtración de Radiación

Note: Document originally drafted in the English language.

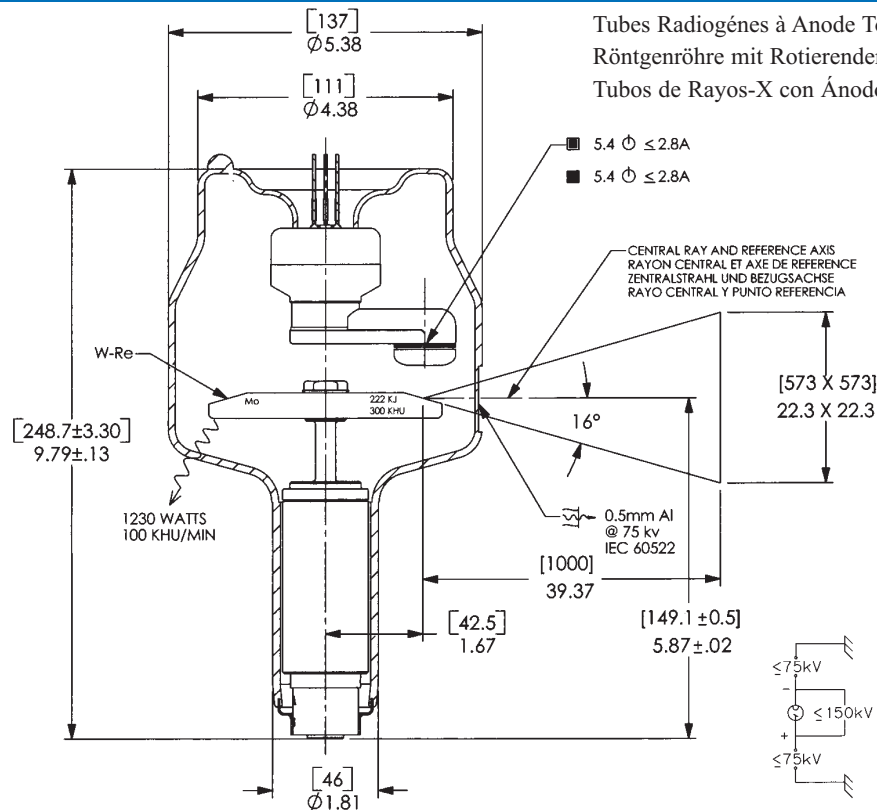

Tubes Radiogènes à Anode Tournante  
 Röntgenröhre mit Rotierender Anode  
 Tubos de Rayos-X con Ánodo Giratorio

■ 5.4  $\phi \leq 2.8A$   
■ 5.4  $\phi \leq 2.8A$

CENTRAL RAY AND REFERENCE AXIS  
RAYON CENTRAL ET AXE DE REFERENCE  
ZENTRALSTRAHL UND BEZUGSACHSE  
RAYO CENTRAL Y PUNTO REFERENCIA

[573 X 573]  
22.3 X 22.3

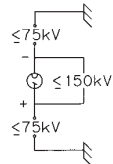

Product Description	Description du Produit	Produktbeschreibung	Descripcion del Producto
<p>The A-152 is a 4.0" (102 mm) 150 kV, 222 kJ (300 kHU) maximum anode heat content, rotating anode insert. This insert is specifically designed for heavy duty general radio-graphic and fluoro/spotfilm procedures. The insert features a 16° rhenium-tungsten molybdenum target and is available with the following nominal focal spots:</p> <p style="text-align: center;">1.0 - 2.0 IEC 60336</p> <p><b>Nominal Anode Input Power</b> Small - 58 kW IEC 60613 Large - 120 kW IEC 60613 For the equivalent anode input power of 125 Watts</p> <p>This insert is intended for use in Varian B-130 and B-150 housings.</p>	<p>Le tube A-152, à anode tournante de 102 mm, (4.0 pouces), 150 kV, avec une capacité calorifique maximale de 222 kJ (300 kUC) est à usage spécifique pour la radiographie de grande puissance et pour la radio-fluorographie. L'anode composite en Rhénium - Tungstène Molybdène avec pente d'anode de 16° est disponible avec les combinaisons focales suivantes:</p> <p style="text-align: center;">1,0 - 2,0 CEI 60336</p> <p><b>Puissance anodique nominale</b> Petit foyer - 58 kW CEI 60613 Grand foyer - 120 kW CEI 60613 Pour la puissance anodique d'équilibre thermique de 125 Watts</p> <p>Ce tube est essentiellement destiné à être employé dans les gaines Varian des séries B-130 et B-150.</p>	<p>Die A-152 ist eine 4.0" (102 mm) Doppelfokus Drehanoden-Röntgenröhre, mit einer Wärmespeicherkapazität des Anodentellers von 222 kJ (300 kHU) und einer max. Spannungsfestigkeit von 150 kV. Die Röhre wurde für stark frequentierte Aufnahmearbeitsplätze und für den Durchleuchtungs- und Zielgerätebetrieb (1mm FFA) ausgelegt. Der Rhenium, Wolfram, und Molybdän Anodenteller besitzt einen Winkel von 16°. Folgende Brennfleckkombinationen sind lieferbar:</p> <p style="text-align: center;">1.0 - 2.0 IEC 60336</p> <p><b>Nominale Anodenbezugsleistung</b> Klein - 58 kW IEC 60613 Gross - 120 kW IEC 60613 Gilt bei einer Äquivalent - Anodenleistung von 125 Watt</p> <p>Die Röntgenröhre ist für den Einbau in die Varian Strahlerhauben B130 und B-150 vorgesehen.</p>	<p>El A-152 es un tubo de ánodo giratorio de 102 mm, (4.0"), 150 kV, 222 kJ (300 kUC) diseñado específicamente para procedimientos generales de alto volumen en radiografía y fluoroscopia. Consta de un objetivo de renio, tungsteno y molibdeno con una pendiente de 16 grados. Disponible con las siguientes combinaciones de marcas focales:</p> <p style="text-align: center;">1.0 - 2.0 IEC 60336</p> <p><b>Potencia nominal de entrada del anodo</b> Foco fine - 58 kW IEC 60613 Foco grueso - 120 kW IEC 60613 Para una potencia equivalente del anodo de 125 W</p> <p>Este tubo es diseñado, para uso en los encajes Varian de la serie B-130 - B-150.</p>

Manufactured by Varian Medical Systems  
Fabrique par Varian Medical Systems  
Hergestellt von Varian Medical Systems  
Fabricado por Varian Medical Systems

Specifications subject to change without notice.  
Spécifications susceptibles d'être modifiées sans préavis.  
Technische Daten ohne Gewähr.  
Especificaciones sujetas a cambio sin previo aviso.

**3 Ø Constant Potential**  
**50 Hz.**

Abaques de charge pour pose unique CEI 60613  
Brennfleck - Belastungskurven IEC 60613  
Diagramas de Exposición Radiográfica IEC 60613

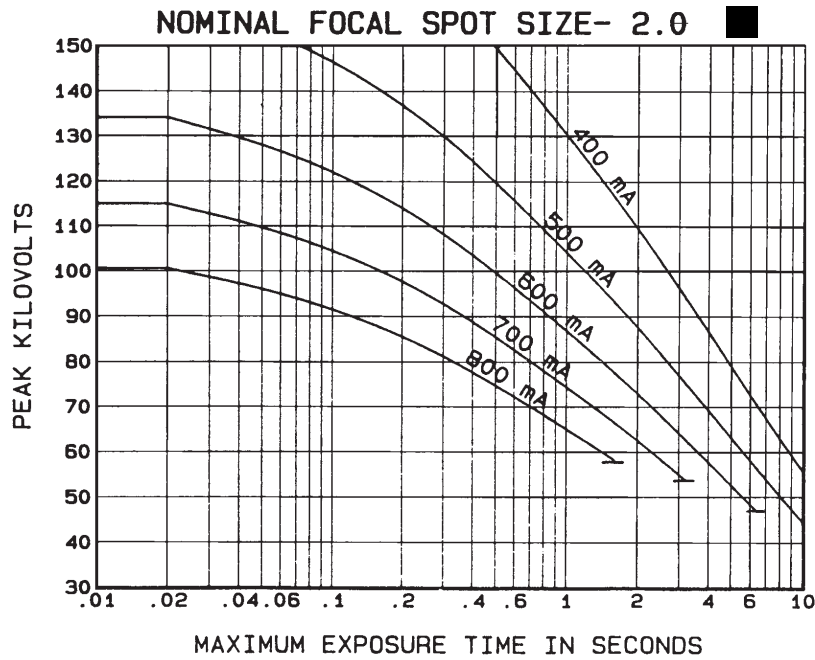
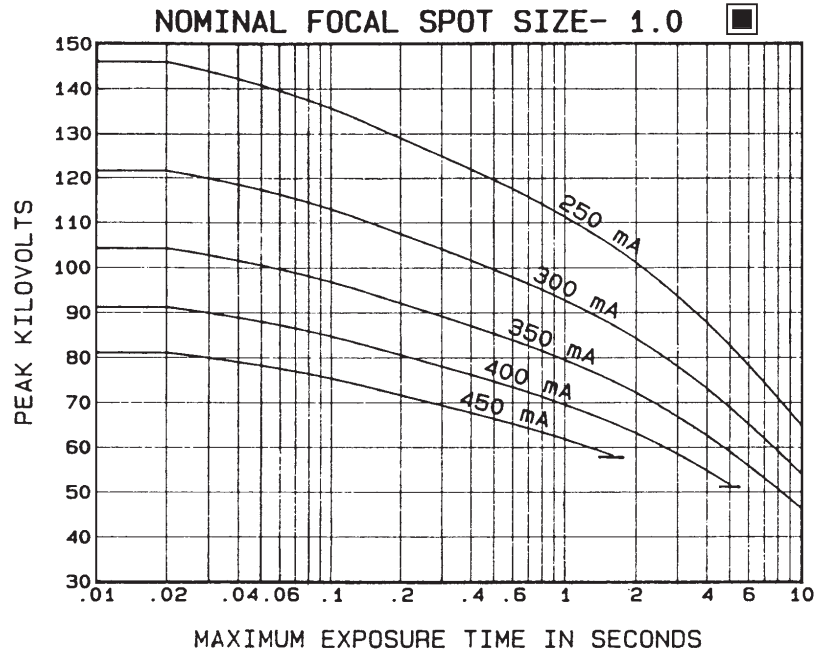

Nominal anode input power for the anode heat content 40%. IEC 60613

Puissance calorifique nominale de l'anode: 40%, CEI 60613

Thermische Anodenbezugsleistung bei einer Wärmespeicherung von 40%. IEC 60613

Aproximadamente el poder de penetracion para obtener un almacenaje de calor del anodo de 40%. IEC 60613

# 3 Ø Constant Potential

60 Hz.

Abaques de charge pour pose unique CEI 60613  
Brennfleck - Belastungskurven IEC 60613  
Diagramas de Exposición Radiográfica IEC 60613

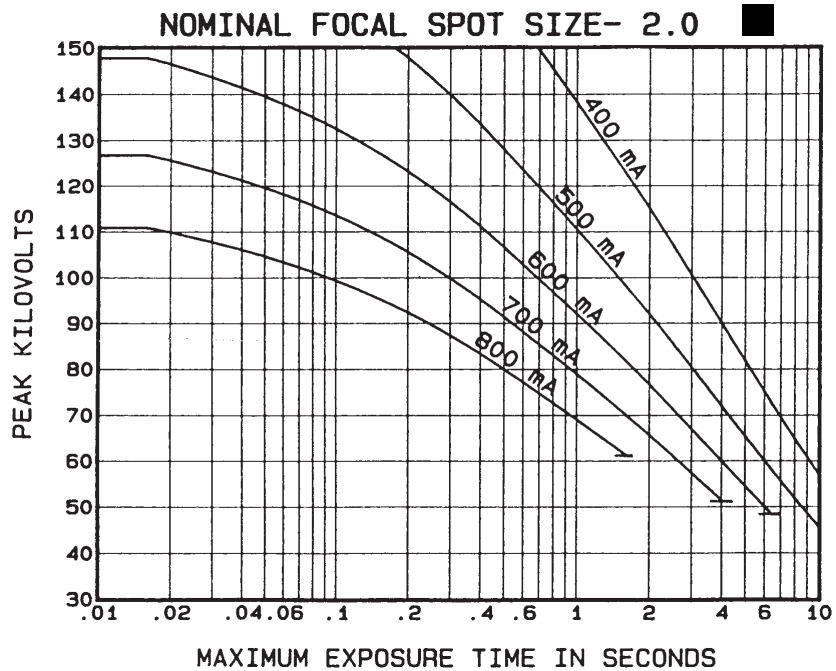
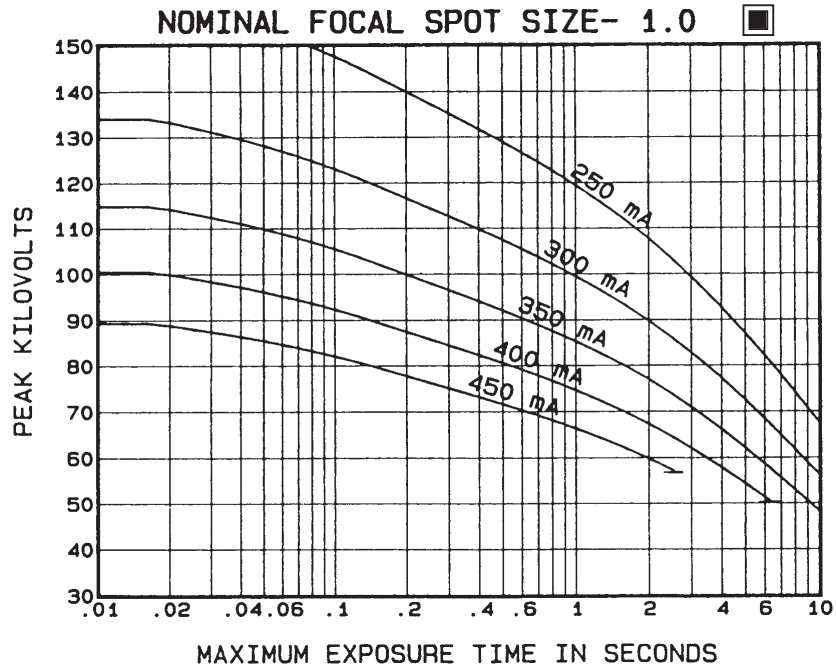

Nominal anode input power for the anode heat content 40%. IEC 60613

Puissance calorifique nominale de l'anode: 40%, CEI 60613

Thermische Anodenbezugsleistung bei einer Wärmespeicherung von 40%. IEC 60613

Aproximadamente el poder de penetracion para obtener un almacenaje de calor del anodo de 40%. IEC 60613

**3 Ø Constant Potential**  
**150 Hz.**

Abaques de charge pour pose unique CEI 60613  
Brennfleck - Belastungskurven IEC 60613  
Diagramas de Exposición Radiográfica IEC 60613

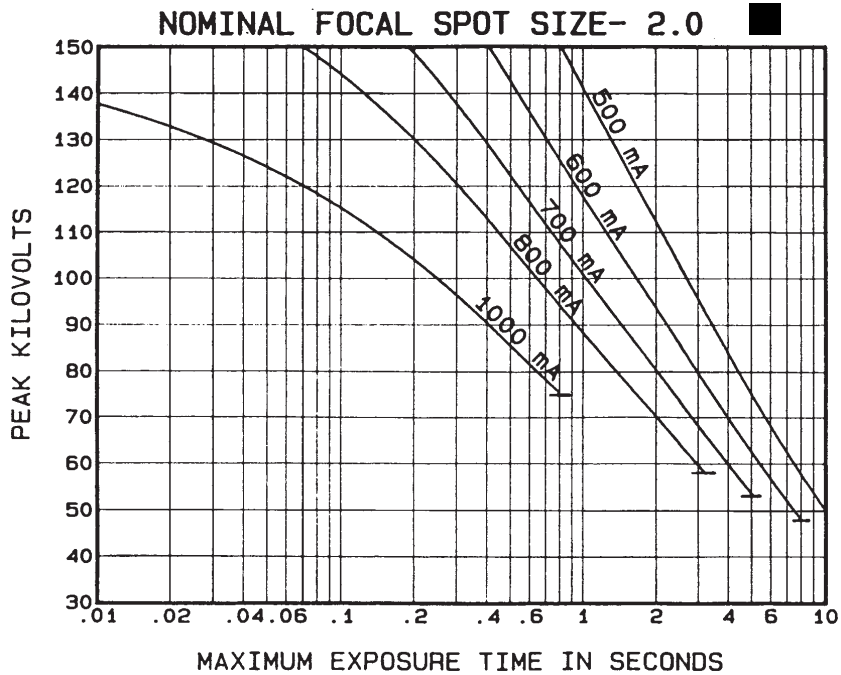
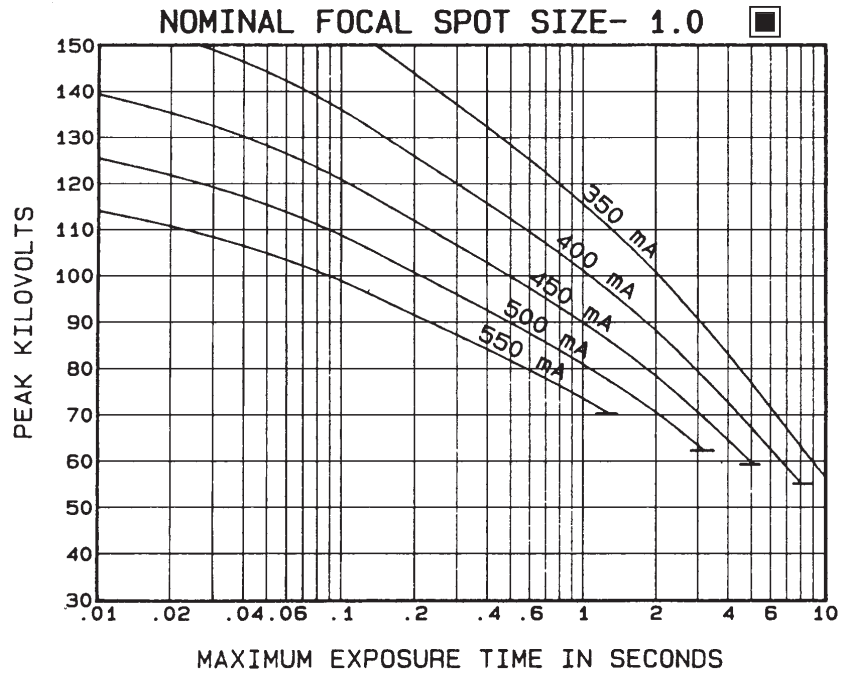

Nominal anode input power for the anode heat content 40%. IEC 60613

Puissance calorifique nominale de l'anode: 40%, CEI 60613

Thermische Anodenbezugsleistung bei einer Wärmespeicherung von 40%. IEC 60613

Aproximadamente el poder de penetracion para obtener un almacenaje de calor del anodo de 40%. IEC 60613

### 3 Ø Constant Potential

180 Hz.

Abaques de charge pour pose unique CEI 60613

Brennfleck - Belastungskurven IEC 60613

Diagramas de Exposición Radiográfica IEC 60613

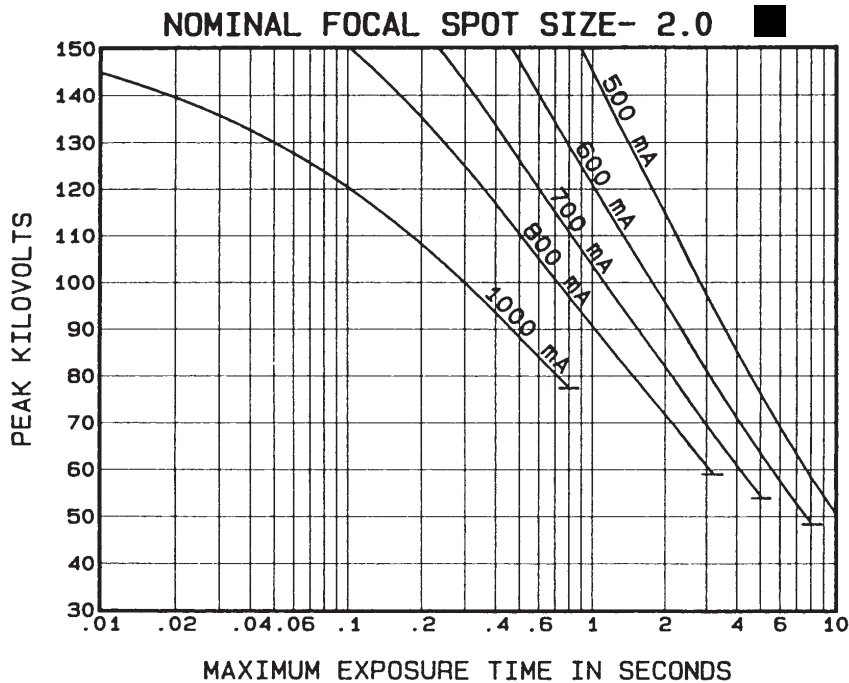
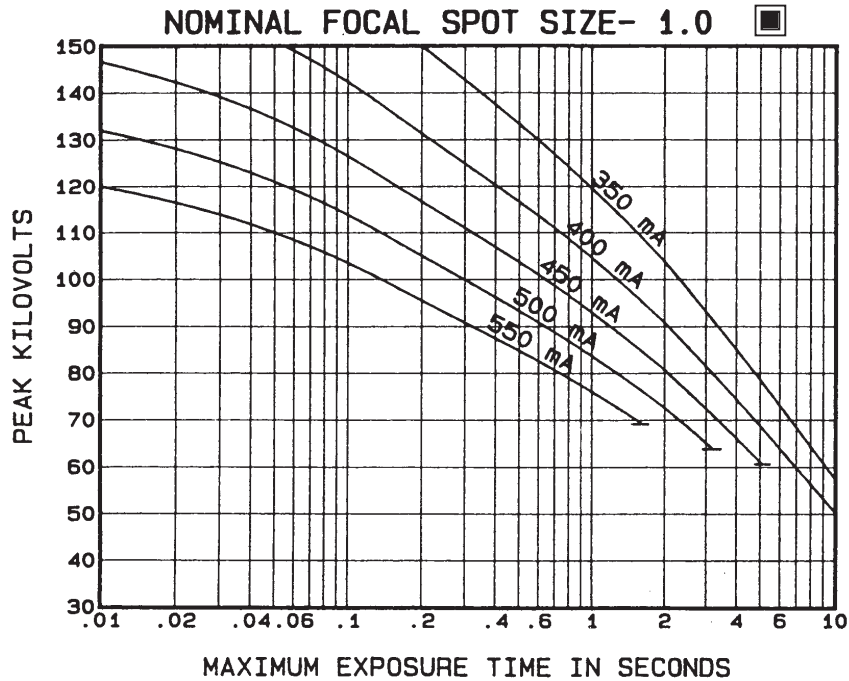

Nominal anode input power for the anode heat content 40%. IEC 60613

Puissance calorifique nominale de l'anode: 40%, CEI 60613

Thermische Anodenbezugsleistung bei einer Wärmespeicherung von 40%. IEC 60613

Aproximadamente el poder de penetracion para obtener un almacenaje de calor del anodo de 40%. IEC 60613

## ANGIOGRAPHIC RATINGS

### HOW TO USE ANGIOGRAPHIC CHARTS

**General:** Serial Radiography puts a severe demand on the x-ray tube due to the large number of exposures made in rapid succession. Intervals between exposures are fixed and so short that it is not possible for the anode track to cool to any extent during the exposure series. Therefore, the temperature of the anode track increases from exposure to exposure. The kW values used in the angiographic charts have been determined to prevent damage to the anode. The angiographic rating charts are usable to 100% anode heat storage. Exceeding 100% anode heat storage will cause anode track erosion with high risk of tube destruction.

#### Definition of Terms

**Number of Exposures in Series:** The number of exposures made in succession or the number of exposures made during one contrast injection.

**Exposure Rate:** The number of exposures made per second. For a series of exposures where the exposure rate changes, it must be assumed that all exposures will be made at the maximum rate. For example, if during a series 10 exposures will occur at one per second and 30 exposures at 4 per second, use the kW ratings in the 40 exposure column at 4 per second rate.

**Exposure Time:** Time in seconds of each exposure.

#### USING THE CHARTS:

##### Select Correct Chart:

**Determine the number of exposures in Series:** With cut film angiography the number of exposures are known, however in Digital Angiography the number of exposures commonly are not known. When determining the number of exposures, assume worst case or past history.

**Note:** Most angiographic x-ray tubes fail from underestimating the number of exposures made in a series.

**Determine kW of each exposure in Series:** Referring to chart —find block under “Number of Exposures in Series” that is greater than or equal to expected number of exposures in Series. On left side directly opposite this block under “Exposure Rate per Second” column, select maximum rate per second that will be used for the exposure series. At the intersection of exposure rate and exposure time in seconds, find maximum kW allowed for each exposure.

**kW = pkV x mA:** The kW of the exposure can be any combination of mA and pkV allowed by the Radiographic and Filament Emission charts.

For Example: 80 pkV and 500 mA = 40 kW

**Example:** From chart A-152 150/180 Hz 3 Phase 2.0 Focal Spot, determine kW allowed with following known factors.  
Maximum number of exposures .....40  
Exposure time .050 second (50 milliseconds)  
Maximum Exposure per second .....4

From chart find 40 exposure block. On left side directly opposite this block under “Exposure Rate per Second” column, select 4 exposures per second. Find .050 seconds at top of chart. At intersection of exposure rate line and exposure time, find 55.0 kW.

1.0 Focal Spot 3Ø 16 Degrees 50/60 Hz  
1,0 Dimension Focale 3Ø 16 Degrés 50/60 Hz  
1.0 Brennpunkt 3Ø 16 Grad 50/60 Hz  
1.0 De Marcas Focales 3Ø 16 Grados 50/60 Hz

Caractéristiques Pour L'Angiographie CEI 60613  
Angiographische Nennleistungen IEC 60613  
Gradaciones Angiografica IEC 60613

Exposure rate per second	Tube load (kW) as a function of the exposure time (seconds) of the individual radiographs of the series															Number of exposures in series
	0.010	0.020	0.030	0.040	0.050	0.060	0.080	0.100	0.120	0.140	0.160	0.180	0.200	0.225	0.250	
1	32.1	31.7	31.0	30.3	29.7	29.1	28.1	27.2	26.5	25.7	25.1	24.5	23.9	23.3	22.7	10
2	32.0	31.6	30.8	30.0	29.4	28.8	27.7	26.8	25.9	25.2	24.5	23.8	23.3	22.6	22.0	
3	32.0	31.5	30.6	29.8	29.1	28.5	27.3	26.4	25.5	24.7	24.0	23.3				
4	31.9	31.3	30.4	29.6	28.8	28.2	27.0	26.0	25.1	24.2						
8	31.6	30.9	29.8	28.8	27.9	27.1										
15	31.3	30.2	28.8	27.6												
30	30.7	29.1														
1	31.8	31.2	30.1	29.2	28.4	27.7	26.3	25.2	24.2	23.2	22.4	21.6	20.9	20.1	19.4	20
2	31.7	31.0	29.9	28.9	28.1	27.3	25.9	24.7	23.6	22.7	21.8	21.0	20.3	19.5	18.7	
3	31.6	30.8	29.7	28.7	27.8	26.9	25.5	24.2	23.1	22.1	21.3	20.5				
4	31.5	30.7	29.5	28.4	27.5	26.6	25.1	23.8	22.7	21.7						
8	31.2	30.1	28.7	27.5	26.4	25.4										
15	30.8	29.2	27.6	26.1												
30	30.0	27.9														
1	31.2	30.1	28.6	27.4	26.3	25.2	23.5	22.0	20.7	19.6	17.2	15.3	13.8	12.2	11.0	40
2	31.1	29.9	28.4	27.1	25.9	24.9	23.1	21.5	20.2	19.1	17.2	15.3	13.8	12.2	11.0	
3	31.0	29.7	28.2	26.8	25.6	24.5	22.7	21.1	19.8	18.6	17.2	15.3				
4	30.9	29.5	27.9	26.5	25.3	24.2	22.3	20.7	19.4	18.2						
8	30.6	28.9	27.1	25.5	24.2	23.0										
15	30.0	27.9	25.8	24.1												
30	29.0	26.3														
1	30.7	29.1	27.3	25.8	24.4	23.2	21.2	18.3	15.3	13.1	11.5	10.2	9.2	8.1	7.3	60
2	30.6	28.9	27.1	25.5	24.1	22.9	20.8	18.3	15.3	13.1	11.5	10.2	9.2	8.1	7.3	
3	30.5	28.7	26.8	25.2	23.8	22.6	20.5	18.3	15.3	13.1	11.5	10.2				
4	30.4	28.5	26.6	24.9	23.5	22.3	20.1	18.3	15.3	13.1						
8	30.0	27.8	25.7	23.9	22.4	21.1										
15	29.4	26.9	24.5	22.5												
30	28.3	25.2														
1	30.1	28.1	26.1	24.3	22.8	21.5	17.2	13.8	11.5	9.8	8.6	7.6	6.9	6.1	5.5	80
2	30.0	28.0	25.9	24.1	22.5	21.2	17.2	13.8	11.5	9.8	8.6	7.6	6.9	6.1	5.5	
3	29.9	27.8	25.6	23.8	22.3	20.9	17.2	13.8	11.5	9.8	8.6	7.6				
4	29.8	27.6	25.4	23.6	22.0	20.6	17.2	13.8	11.5	9.8						
8	29.4	26.9	24.6	22.6	21.0	19.6										
15	28.8	25.9	23.4	21.3												
30	27.7	24.2														
1	29.6	27.3	25.0	23.1	21.5	18.3	13.8	11.0	9.2	7.9	6.9	6.1	5.5	4.9	4.4	100
2	29.5	27.1	24.8	22.8	21.2	18.3	13.8	11.0	9.2	7.9	6.9	6.1	5.5	4.9	4.4	
3	29.4	26.9	24.5	22.6	20.9	18.3	13.8	11.0	9.2	7.9	6.9	6.1				
4	29.3	26.7	24.3	22.3	20.7	18.3	13.8	11.0	9.2	7.9						
8	28.9	26.1	23.5	21.4	19.7	18.3										
15	28.3	25.1	22.4	20.2												
30	27.2	23.4														
1	28.5	25.3	22.6	18.3	14.7	12.2	9.2	7.3	6.1	5.2	4.6	4.1	3.7	3.3	2.9	150
2	28.3	25.2	22.4	18.3	14.7	12.2	9.2	7.3	6.1	5.2	4.6	4.1	3.7	3.3	2.9	
3	28.2	25.0	22.2	18.3	14.7	12.2	9.2	7.3	6.1	5.2	4.6	4.1				
4	28.1	24.8	22.0	18.3	14.7	12.2	9.2	7.3	6.1	5.2						
8	27.7	24.2	21.3	18.3	14.7	12.2										
15	27.1	23.3	20.3	17.9												
30	26.0	21.7														

**Note:**  
1. (kW) of Exposure Equals mA x kV.  
For Example: 70 kV x 300 mA = 21 kW.  
2. Exposures less than .010 seconds will have a kW rating same as .010 seconds.

**Remarque:**  
1. (kW) en exposition égale kV x mA.  
Par exemple: 70 kV x 300 mA = 21 kW.  
2. Les expositions inférieures à 0.010 sec. ont les mêmes valeurs en kW que celles de 0.010 sec.

**Anmerkungen:**  
1. (kW) der Belichtung ist gleich mA x kV.  
Zum Beispiel: 70 kV x 300 mA = 21 kW.  
2. Belichtungen von weniger als .010 Sekunden haben die gleichen kW Werte wie die von .010 Sekunden.

**Nota:**  
1. (kW) De exposición se calcula multiplicando mA x kV-por ejemplo: 70 kV x 300 mA = 21 kW.  
2. Para exposición de menos de .010 segundos, el resultado en (kW) sería lo mismo que el de .010 segundos.

Nominal anode input power for the anode heat content 70%. IEC 60613

Puissance calorifique nominale de l'anode: 70%, CEI 60613

Thermische Anodenbezugsleistung bei einer Wärmespeicherung von 70%. IEC 60613

Aproximadamente el poder de penetración para obtener un almacenaje de calor del anodo de 70%. IEC 60613

1.0 Focal Spot 3Ø 16 Degrees 150/180 Hz  
1,0 Dimension Focale 3Ø 16 Degrés 150/180 Hz  
1.0 Brennpunkt 3Ø 16 Grad 150/180 Hz  
1.0 De Marcas Focales 3Ø 16 Grados 150/80 Hz

Caractéristiques Pour L'Angiographie CEI 60613  
Angiographische Nennleistungen IEC 60613  
Gradaciones Angiografica IEC 60613

Exposure rate per second	Tube load (kW) as a function of the exposure time (seconds) of the individual radiographs of the series															Number of exposures in series
	0.010	0.020	0.030	0.040	0.050	0.060	0.080	0.100	0.120	0.140	0.160	0.180	0.200	0.225	0.250	
1	54.7	52.0	50.0	48.3	46.8	45.4	43.1	41.1	39.4	37.8	36.4	35.2	34.1	32.8	31.6	10
2	54.5	51.6	49.5	47.7	46.1	44.7	42.2	40.1	38.3	36.6	35.2	33.9	32.7	31.4	30.3	
3	54.3	51.3	49.0	47.1	45.4	43.9	41.3	39.2	37.3	35.6	34.1	32.8	—	—	—	
4	54.1	50.9	48.5	46.5	44.8	43.2	40.5	38.3	36.4	34.7	—	—	—	—	—	
8	53.3	49.7	46.9	44.5	42.5	40.8	—	—	—	—	—	—	—	—	—	
15	52.3	48.0	44.6	41.9	—	—	—	—	—	—	—	—	—	—	—	
30	50.7	45.4	—	—	—	—	—	—	—	—	—	—	—	—	—	
1	53.8	50.4	47.8	45.6	43.7	42.0	39.1	36.6	34.5	32.7	31.0	29.6	27.5	24.4	22.0	20
2	53.6	50.0	47.3	45.0	43.0	41.2	38.1	35.6	33.4	31.6	29.9	28.5	27.2	24.4	22.0	
3	53.3	49.6	46.7	44.3	42.2	40.4	37.3	34.7	32.5	30.6	28.9	27.4	—	—	—	
4	53.1	49.2	46.2	43.7	41.5	39.6	36.4	33.8	31.6	29.7	—	—	—	—	—	
8	52.2	47.7	44.3	41.5	39.1	37.0	—	—	—	—	—	—	—	—	—	
15	50.9	45.6	41.7	38.5	—	—	—	—	—	—	—	—	—	—	—	
30	48.8	42.3	—	—	—	—	—	—	—	—	—	—	—	—	—	
1	52.2	47.7	44.2	41.3	38.8	36.7	33.1	27.5	22.9	19.6	17.2	15.3	13.8	12.2	11.0	40
2	51.9	47.2	43.6	40.6	38.1	35.9	32.3	27.5	22.9	19.6	17.2	15.3	13.8	12.2	11.0	
3	51.6	46.8	43.0	40.0	37.4	35.2	31.5	27.5	22.9	19.6	17.2	15.3	—	—	—	
4	51.4	46.3	42.5	39.4	36.8	34.5	30.8	27.5	22.9	19.6	—	—	—	—	—	
8	50.4	44.7	40.5	37.2	34.4	32.1	—	—	—	—	—	—	—	—	—	
15	48.9	42.5	37.8	34.2	—	—	—	—	—	—	—	—	—	—	—	
30	46.4	38.9	—	—	—	—	—	—	—	—	—	—	—	—	—	
1	50.7	45.2	41.1	37.7	35.0	30.6	22.9	18.3	15.3	13.1	11.5	10.2	9.2	8.1	7.3	60
2	50.4	44.8	40.5	37.1	34.3	30.6	22.9	18.3	15.3	13.1	11.5	10.2	9.2	8.1	7.3	
3	50.1	44.3	40.0	36.5	33.7	30.6	22.9	18.3	15.3	13.1	11.5	10.2	—	—	—	
4	49.8	43.9	39.5	36.0	33.1	30.6	22.9	18.3	15.3	13.1	—	—	—	—	—	
8	48.8	42.3	37.6	34.0	31.0	28.6	—	—	—	—	—	—	—	—	—	
15	47.2	40.1	35.0	31.2	—	—	—	—	—	—	—	—	—	—	—	
30	44.6	36.4	—	—	—	—	—	—	—	—	—	—	—	—	—	
1	49.3	43.0	38.4	34.4	27.5	22.9	17.2	13.8	11.5	9.8	8.6	7.6	6.9	6.1	5.5	80
2	49.0	42.6	37.9	34.2	27.5	22.9	17.2	13.8	11.5	9.8	8.6	7.6	6.9	6.1	5.5	
3	48.7	42.1	37.4	33.7	27.5	22.9	17.2	13.8	11.5	9.8	8.6	7.6	—	—	—	
4	48.4	41.7	36.9	33.2	27.5	22.9	17.2	13.8	11.5	9.8	—	—	—	—	—	
8	47.4	40.2	35.2	31.3	27.5	22.9	—	—	—	—	—	—	—	—	—	
15	45.8	38.0	32.7	28.8	—	—	—	—	—	—	—	—	—	—	—	
30	43.1	34.5	—	—	—	—	—	—	—	—	—	—	—	—	—	
1	47.9	41.0	36.0	27.5	22.0	18.3	13.8	11.0	9.2	7.9	6.9	6.1	5.5	4.9	4.4	100
2	47.6	40.6	35.6	27.5	22.0	18.3	13.8	11.0	9.2	7.9	6.9	6.1	5.5	4.9	4.4	
3	47.4	40.2	35.1	27.5	22.0	18.3	13.8	11.0	9.2	7.9	6.9	6.1	—	—	—	
4	47.1	39.8	34.7	27.5	22.0	18.3	13.8	11.0	9.2	7.9	—	—	—	—	—	
8	46.0	38.3	33.1	27.5	22.0	18.3	—	—	—	—	—	—	—	—	—	
15	44.5	36.3	30.8	26.8	—	—	—	—	—	—	—	—	—	—	—	
30	41.8	32.9	—	—	—	—	—	—	—	—	—	—	—	—	—	
1	44.9	36.7	24.4	18.3	14.7	12.2	9.2	7.3	6.1	5.2	4.6	4.1	3.7	3.3	2.9	150
2	44.6	36.4	24.4	18.3	14.7	12.2	9.2	7.3	6.1	5.2	4.6	4.1	3.7	3.3	2.9	
3	44.4	36.0	24.4	18.3	14.7	12.2	9.2	7.3	6.1	5.2	4.6	4.1	—	—	—	
4	44.1	35.7	24.4	18.3	14.7	12.2	9.2	7.3	6.1	5.2	—	—	—	—	—	
8	43.1	34.4	24.4	18.3	14.7	12.2	—	—	—	—	—	—	—	—	—	
15	41.6	32.6	24.4	18.3	—	—	—	—	—	—	—	—	—	—	—	
30	39.1	29.6	—	—	—	—	—	—	—	—	—	—	—	—	—	

**Note:**

1. (kW) of Exposure Equals mA x kV.  
For Example: 70 kV x 300 mA = 21 kW.  
2. Exposures less than .010 seconds will have a kW rating same as .010 seconds.

**Remarque:**

1. (kW) en exposition égale kV x mA.  
Par exemple: 70 kV x 300 mA = 21 kW.  
2. Les expositions inférieures à 0.010 sec. ont les mêmes valeurs en kW que celles de 0.010 sec.

**Anmerkungen:**

1. (kW) der Belichtung ist gleich mA x kV.  
Zum Beispiel: 70 kV x 300 mA = 21 kW.  
2. Belichtungen von weniger als .010 Sekunden haben die gleichen kW Werte wie die von .010 Sekunden.

**Nota:**

1. (kW) De exposición se calcula multiplicando mA x kV-por ejemplo: 70 kV x 300 mA = 21 kW.  
2. Para exposición de menos de .010 segundos, el resultado en (kW) sería lo mismo que el de .010 segundos.

Nominal anode input power for the anode heat content 70%. IEC 60613

Puissance calorifique nominale de l'anode: 70%, CEI 60613

Thermische Anodenbezugsleistung bei einer Wärmespeicherung von 70%. IEC 60613

Aproximadamente el poder de penetración para obtener un almacenaje de calor del anodo de 70%. IEC 60613

2.0 Focal Spot 3Ø 16 Degrees 50/60 Hz  
2,0 Dimension Focale 3Ø 16 Degrés 50/60 Hz  
2.0 Brennpunkt 3Ø 16 Grad 50/60 Hz  
2.0 De Marcas Focales 3Ø 16 Grados 50/60 Hz

Caractéristiques Pour L'Angiographie CEI 60613  
Angiographische Nennleistungen IEC 60613  
Gradaciones Angiografica IEC 60613

Exposure rate per second	Tube load (kW) as a function of the exposure time (seconds) of the individual radiographs of the series															Number of exposures in series
	0.010	0.020	0.030	0.040	0.050	0.060	0.080	0.100	0.120	0.140	0.160	0.180	0.200	0.225	0.250	
1	70.9	69.2	66.3	63.8	61.6	59.6	56.2	53.3	50.7	48.4	46.4	44.5	42.9	40.9	39.2	10
2	70.5	68.4	65.4	62.6	60.2	58.1	54.4	51.3	48.6	46.3	44.2	42.3	40.6	38.6	36.9	
3	70.2	67.9	64.6	61.6	59.1	56.8	53.0	49.7	46.9	44.4	42.3	40.4	—	—	—	
4	69.9	67.3	63.8	60.8	58.1	55.8	51.7	48.4	45.5	43.0	—	—	—	—	—	
8	69.0	65.7	61.6	58.1	55.1	52.5	—	—	—	—	—	—	—	—	—	
15	67.9	63.7	59.1	55.1	—	—	—	—	—	—	—	—	—	—	—	
30	66.6	61.3	—	—	—	—	—	—	—	—	—	—	—	—	—	
1	69.4	66.4	62.6	59.3	56.4	53.8	49.5	45.9	42.9	39.3	34.4	30.6	27.5	24.4	22.0	20
2	69.0	65.6	61.5	58.0	55.0	52.3	47.8	44.1	41.0	38.4	34.4	30.6	27.5	24.4	22.0	
3	68.6	64.9	60.6	56.9	53.7	51.0	46.3	42.6	39.4	36.7	34.4	30.6	—	—	—	
4	68.2	64.2	59.8	55.9	52.7	49.8	45.1	41.3	38.1	35.4	—	—	—	—	—	
8	67.0	62.1	57.0	52.8	49.2	46.2	—	—	—	—	—	—	—	—	—	
15	65.4	59.4	53.7	49.0	—	—	—	—	—	—	—	—	—	—	—	
30	63.1	55.7	—	—	—	—	—	—	—	—	—	—	—	—	—	
1	66.7	61.7	56.4	52.1	48.5	45.4	34.4	27.5	22.9	19.6	17.2	15.3	13.8	12.2	11.0	40
2	66.2	60.8	55.4	50.9	47.2	44.0	34.4	27.5	22.9	19.6	17.2	15.3	13.8	12.2	11.0	
3	65.8	60.1	54.5	49.9	46.1	42.9	34.4	27.5	22.9	19.6	17.2	15.3	—	—	—	
4	65.4	59.4	53.6	49.0	45.1	41.9	34.4	27.5	22.9	19.6	—	—	—	—	—	
8	63.9	57.1	50.9	45.9	41.9	38.6	—	—	—	—	—	—	—	—	—	
15	62.0	54.0	47.3	42.1	—	—	—	—	—	—	—	—	—	—	—	
30	58.9	49.5	—	—	—	—	—	—	—	—	—	—	—	—	—	
1	64.3	57.6	51.5	45.8	36.7	30.6	22.9	18.3	15.3	13.1	11.5	10.2	9.2	8.1	7.3	60
2	63.8	56.8	50.5	45.5	36.7	30.6	22.9	18.3	15.3	13.1	11.5	10.2	9.2	8.1	7.3	
3	63.3	56.1	49.7	44.6	36.7	30.6	22.9	18.3	15.3	13.1	11.5	10.2	—	—	—	
4	62.9	55.4	48.9	43.8	36.7	30.6	22.9	18.3	15.3	13.1	—	—	—	—	—	
8	61.4	53.1	46.3	41.0	36.7	30.6	—	—	—	—	—	—	—	—	—	
15	59.3	50.1	42.9	37.5	—	—	—	—	—	—	—	—	—	—	—	
30	56.0	45.5	—	—	—	—	—	—	—	—	—	—	—	—	—	
1	62.0	54.1	45.8	34.4	27.5	22.9	17.2	13.8	11.5	9.8	8.6	7.6	6.9	6.1	5.5	80
2	61.5	53.3	45.8	34.4	27.5	22.9	17.2	13.8	11.5	9.8	8.6	7.6	6.9	6.1	5.5	
3	61.1	52.6	45.7	34.4	27.5	22.9	17.2	13.8	11.5	9.8	8.6	7.6	—	—	—	
4	60.6	52.0	45.0	34.4	27.5	22.9	17.2	13.8	11.5	9.8	—	—	—	—	—	
8	59.1	49.8	42.6	34.4	27.5	22.9	—	—	—	—	—	—	—	—	—	
15	57.0	46.9	39.4	34.0	—	—	—	—	—	—	—	—	—	—	—	
30	53.6	42.5	—	—	—	—	—	—	—	—	—	—	—	—	—	
1	59.9	50.9	36.7	27.5	22.0	18.3	13.8	11.0	9.2	7.9	6.9	6.1	5.5	4.9	4.4	100
2	59.4	50.2	36.7	27.5	22.0	18.3	13.8	11.0	9.2	7.9	6.9	6.1	5.5	4.9	4.4	
3	59.0	49.6	36.7	27.5	22.0	18.3	13.8	11.0	9.2	7.9	6.9	6.1	—	—	—	
4	58.6	49.0	36.7	27.5	22.0	18.3	13.8	11.0	9.2	7.9	—	—	—	—	—	
8	57.1	47.0	36.7	27.5	22.0	18.3	—	—	—	—	—	—	—	—	—	
15	55.0	44.2	36.6	27.5	—	—	—	—	—	—	—	—	—	—	—	
30	51.5	39.9	—	—	—	—	—	—	—	—	—	—	—	—	—	
1	55.2	36.7	24.4	18.3	14.7	12.2	9.2	7.3	6.1	5.2	4.6	4.1	3.7	3.3	2.9	150
2	54.8	36.7	24.4	18.3	14.7	12.2	9.2	7.3	6.1	5.2	4.6	4.1	3.7	3.3	2.9	
3	54.4	36.7	24.4	18.3	14.7	12.2	9.2	7.3	6.1	5.2	4.6	4.1	—	—	—	
4	54.0	36.7	24.4	18.3	14.7	12.2	9.2	7.3	6.1	5.2	—	—	—	—	—	
8	52.6	36.7	24.4	18.3	14.7	12.2	—	—	—	—	—	—	—	—	—	
15	50.6	36.7	24.4	18.3	—	—	—	—	—	—	—	—	—	—	—	
30	47.3	35.1	—	—	—	—	—	—	—	—	—	—	—	—	—	

**Note:**

1. (kW) of Exposure Equals mA x kV.  
For Example: 70 kV x 300 mA = 21 kW.  
2. Exposures less than .010 seconds will have a kW rating same as .010 seconds.

**Remarque:**

1. (kW) en exposition égale kV x mA.  
Par exemple: 70 kV x 300 mA = 21 kW.  
2. Les expositions inférieures à 0.010 sec. ont les mêmes valeurs en kW que celles de 0.010 sec.

**Anmerkungen:**

1. (kW) der Belichtung ist gleich mA x kV.  
Zum Beispiel: 70 kV x 300 mA = 21 kW.  
2. Belichtungen von weniger als .010 Sekunden haben die gleichen kW Werte wie die von .010 Sekunden.

**Nota:**

1. (kW) De exposición se calcula multiplicando mA x kV-por ejemplo: 70 kV x 300 mA = 21 kW.  
2. Para exposición de menos de .010 segundos, el resultado en (kW) sería lo mismo que el de .010 segundos.

Nominal anode input power for the anode heat content 70%. IEC 60613

Puissance calorifique nominale de l'anode: 70%, CEI 60613

Thermische Anodenbezugsleistung bei einer Wärmespeicherung von 70%. IEC 60613

Aproximadamente el poder de penetración para obtener un almacenaje de calor del anodo de 70%. IEC 60613

2.0 Focal Spot 3Ø 16 Degrees 150/180 Hz  
2,0 Dimension Focale 3Ø 16 Degrés 150/180 Hz  
2.0 Brennpunkt 3Ø 16 Grad 150/1180 Hz  
2.0 De Marcas Focales 3Ø 16 Grados 150/180 Hz

Caractéristiques Pour L'Angiographie CEI 60613  
Angiographische Nennleistungen IEC 60613  
Gradaciones Angiografica IEC 60613

Exposure rate per second	Tube load (kW) as a function of the exposure time (seconds) of the individual radiographs of the series															Number of exposures in series
	0.010	0.020	0.030	0.040	0.050	0.060	0.080	0.100	0.120	0.140	0.160	0.180	0.200	0.225	0.250	
1	119.0	109.6	102.6	96.9	92.1	87.8	80.7	74.8	69.9	65.7	62.0	58.8	55.0	48.9	44.0	10
2	117.9	107.8	100.9	94.2	89.1	84.6	77.1	71.1	66.1	61.8	58.1	54.9	52.0	48.9	44.0	
3	117.1	106.4	98.5	92.1	86.6	82.0	74.2	68.0	62.9	58.5	54.9	51.7	_____	_____	_____	
4	116.3	105.1	96.8	90.1	84.5	79.7	71.8	65.5	60.4	56.1	_____	_____	_____	_____	_____	
8	113.8	101.1	91.8	84.4	78.3	73.2	_____	_____	_____	_____	_____	_____	_____	_____	_____	
15	110.8	96.5	86.2	78.2	_____	_____	_____	_____	_____	_____	_____	_____	_____	_____	_____	
30	107.2	91.2	_____	_____	_____	_____	_____	_____	_____	_____	_____	_____	_____	_____	_____	
1	114.9	102.9	94.0	86.9	80.9	75.9	67.6	55.0	45.8	39.3	34.4	30.6	27.5	24.4	22.0	20
2	113.7	100.9	91.6	84.1	78.0	72.8	64.5	55.0	45.8	39.3	34.4	30.6	27.5	24.4	22.0	
3	112.6	99.3	89.5	81.9	75.6	70.3	61.8	55.0	45.8	39.3	34.4	30.6	_____	_____	_____	
4	111.6	97.7	87.7	79.9	73.5	68.1	59.6	53.1	45.8	39.3	_____	_____	_____	_____	_____	
8	108.4	92.9	82.0	73.6	67.0	61.5	_____	_____	_____	_____	_____	_____	_____	_____	_____	
15	104.3	87.0	75.2	66.5	_____	_____	_____	_____	_____	_____	_____	_____	_____	_____	_____	
30	98.5	79.3	_____	_____	_____	_____	_____	_____	_____	_____	_____	_____	_____	_____	_____	
1	107.7	91.9	80.8	68.8	55.0	45.8	34.4	27.5	22.9	19.6	17.2	15.3	13.8	12.2	11.0	40
2	106.4	90.0	78.6	68.8	55.0	45.8	34.4	27.5	22.9	19.6	17.2	15.3	13.8	12.2	11.0	
3	105.3	88.4	76.8	68.1	55.0	45.8	34.4	27.5	22.9	19.6	17.2	15.3	_____	_____	_____	
4	104.2	86.9	75.1	66.4	55.0	45.8	34.4	27.5	22.9	19.6	_____	_____	_____	_____	_____	
8	100.6	82.1	69.8	60.9	54.1	45.8	_____	_____	_____	_____	_____	_____	_____	_____	_____	
15	95.8	75.9	63.2	54.3	_____	_____	_____	_____	_____	_____	_____	_____	_____	_____	_____	
30	88.7	67.3	_____	_____	_____	_____	_____	_____	_____	_____	_____	_____	_____	_____	_____	
1	101.5	83.2	61.1	45.8	36.7	30.6	22.9	18.3	15.3	13.1	11.5	10.2	9.2	8.1	7.3	60
2	100.2	81.5	61.1	45.8	36.7	30.6	22.9	18.3	15.3	13.1	11.5	10.2	9.2	8.1	7.3	
3	99.1	80.0	61.1	45.8	36.7	30.6	22.9	18.3	15.3	13.1	11.5	10.2	_____	_____	_____	
4	98.1	78.7	61.1	45.8	36.7	30.6	22.9	18.3	15.3	13.1	_____	_____	_____	_____	_____	
8	94.5	74.2	61.1	45.8	36.7	30.6	_____	_____	_____	_____	_____	_____	_____	_____	_____	
15	89.6	68.3	55.6	45.8	_____	_____	_____	_____	_____	_____	_____	_____	_____	_____	_____	
30	82.2	60.1	_____	_____	_____	_____	_____	_____	_____	_____	_____	_____	_____	_____	_____	
1	96.0	68.8	45.8	34.4	27.5	22.9	17.2	13.8	11.5	9.8	8.6	7.6	6.9	6.1	5.5	80
2	94.7	68.8	45.8	34.4	27.5	22.9	17.2	13.8	11.5	9.8	8.6	7.6	6.9	6.1	5.5	
3	93.7	68.8	45.8	34.4	27.5	22.9	17.2	13.8	11.5	9.8	8.6	7.6	_____	_____	_____	
4	92.7	68.8	45.8	34.4	27.5	22.9	17.2	13.8	11.5	9.8	_____	_____	_____	_____	_____	
8	89.2	67.9	45.8	34.4	27.5	22.9	_____	_____	_____	_____	_____	_____	_____	_____	_____	
15	84.5	62.6	45.8	34.4	_____	_____	_____	_____	_____	_____	_____	_____	_____	_____	_____	
30	77.2	54.9	_____	_____	_____	_____	_____	_____	_____	_____	_____	_____	_____	_____	_____	
1	91.0	55.0	36.7	27.5	22.0	18.3	13.8	11.0	9.2	7.9	6.9	6.1	5.5	4.9	4.4	100
2	89.9	55.0	36.7	27.5	22.0	18.3	13.8	11.0	9.2	7.9	6.9	6.1	5.5	4.9	4.4	
3	88.9	55.0	36.7	27.5	22.0	18.3	13.8	11.0	9.2	7.9	6.9	6.1	_____	_____	_____	
4	87.9	55.0	36.7	27.5	22.0	18.3	13.8	11.0	9.2	7.9	_____	_____	_____	_____	_____	
8	84.6	55.0	36.7	27.5	22.0	18.3	_____	_____	_____	_____	_____	_____	_____	_____	_____	
15	80.1	55.0	36.7	27.5	_____	_____	_____	_____	_____	_____	_____	_____	_____	_____	_____	
30	73.0	50.8	_____	_____	_____	_____	_____	_____	_____	_____	_____	_____	_____	_____	_____	
1	73.3	36.7	24.4	18.3	14.7	12.2	9.2	7.3	6.1	5.2	4.6	4.1	3.7	3.3	2.9	150
2	73.3	36.7	24.4	18.3	14.7	12.2	9.2	7.3	6.1	5.2	4.6	4.1	3.7	3.3	2.9	
3	73.3	36.7	24.4	18.3	14.7	12.2	9.2	7.3	6.1	5.2	4.6	4.1	_____	_____	_____	
4	73.3	36.7	24.4	18.3	14.7	12.2	9.2	7.3	6.1	5.2	_____	_____	_____	_____	_____	
8	73.3	36.7	24.4	18.3	14.7	12.2	_____	_____	_____	_____	_____	_____	_____	_____	_____	
15	71.2	36.7	24.4	18.3	_____	_____	_____	_____	_____	_____	_____	_____	_____	_____	_____	
30	64.8	36.7	_____	_____	_____	_____	_____	_____	_____	_____	_____	_____	_____	_____	_____	

**Note:**  
1. (kW) of Exposure Equals mA x kV.  
For Example: 70 kV x 300 mA = 21 kW.  
2. Exposures less than .010 seconds will have a kW rating same as .010 seconds.

**Remarque:**  
1. (kW) en exposition égale kV x mA.  
Par exemple: 70 kV x 300 mA = 21 kW.  
2. Les expositions inférieures à 0.010 sec. ont les mêmes valeurs en kW que celles de 0.010 sec.

**Anmerkungen:**  
1. (kW) der Belichtung ist gleich mA x kV.  
Zum Beispiel: 70 kV x 300 mA = 21 kW.  
2. Belichtungen von weniger als .010 Sekunden haben die gleichen kW Werte wie die von .010 Sekunden.

**Nota:**  
1. (kW) De exposición se calcula multiplicando mA x kV-po ejemplo: 70 kV x 300 mA = 21 kW.  
2. Para exposición de menos de .010 segundos, el resultado en (kW) sería lo mismo que el de .010 segundos.

Nominal anode input power for the anode heat content 70%. IEC 60613

Puissance calorifique nominale de l'anode: 70%, CEI 60613

Thermische Anodenbezugsleistung bei einer Wärmespeicherung von 70%. IEC 60613

Aproximadamente el poder de penetración para obtener un almacenaje de calor del anodo de 70%. IEC 60613

**3 Ø FULL WAVE**

Abaques d'Émissions des Filaments CEI 60613  
Glühfadenemissionsdiagramm IEC 60613  
Curvas de Emisión de los Filamentos IEC 60613

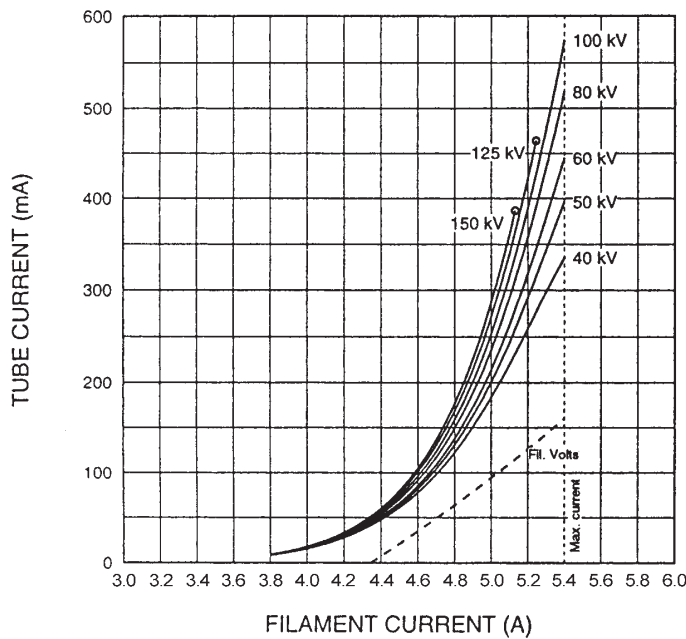

THREE PHASE EMISSION ( $\pm .15$  A)  
A-152            1.0           

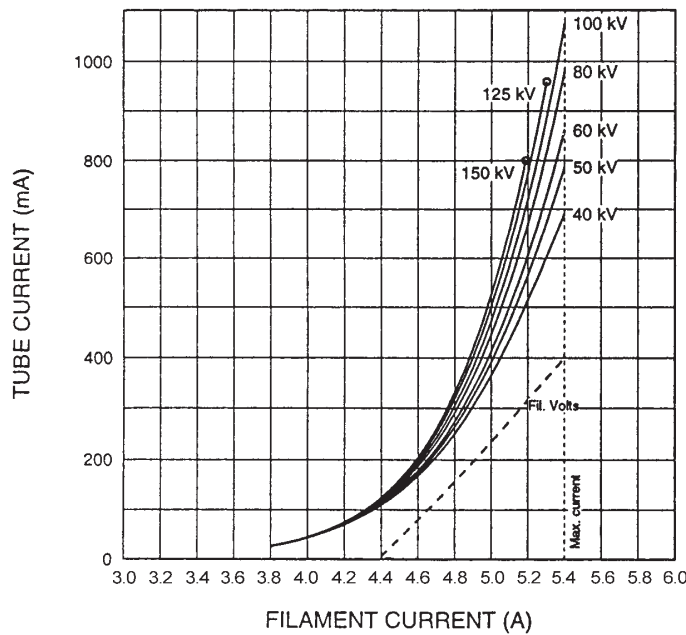

THREE PHASE EMISSION ( $\pm .15$  A)  
A-152            2.0           

Note: When using these emission curves for trial exposures, refer to the power rating curves shown for maximum kV, tube emission, filament current, exposure time, and target speed.

Remarque: Lors de l'utilisation de ces abaques pour des expositions d'essai, référez-vous aux courbes maximales de kV, d'émission du filament, de temps d'exposition et de vitesse de rotation.

Anmerkung: Wenn Sie diese Emissionskurven für Testaufnahmen verwenden, beziehen Sie sich hierbei auf die entsprechenden Nennleistungskurven für max. kV-Werte, Röhrenemission, Heizström, und Anodendrehzahl.

Nota: Si utiliza estas curvas de emisión para exposiciones de prueba, refiérase a las curvas de gradación de potencia para el máximo de kV, tubo de emisión, corriente en los filamentos, tiempo de exposición, y a las curvas de velocidad del objetivo.

Abaques d' Échauffement et de Refroidissement de L'Anode  
Anodenerhitzungs und Kühlungsdiagramm  
Curvas de Calentamiento y Enfriamiento del Anodo

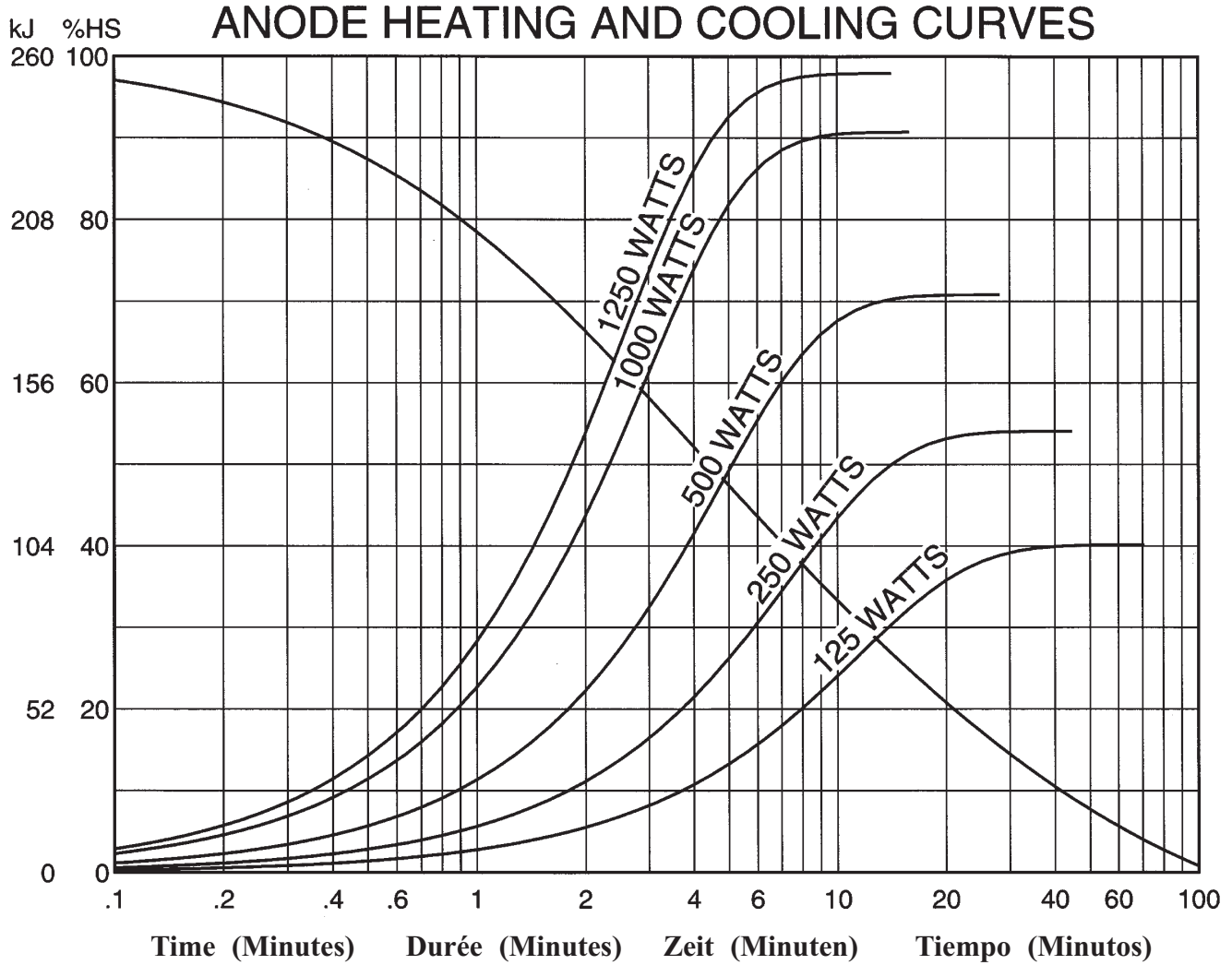

**VARIAN**  
medical systems

**X-RAY  
PRODUCTS**

Salt Lake City, UT  
Charleston, SC

1-801-972-5000  
1-843-767-3005

www.varian.com