

Linatron® K9A High-energy X-ray source

This document specifies the performance and establishes the equipment and installation requirements for operating a 6 and 9 MeV high-energy X-ray source. This source has rapid pulse-to-pulse energy switching for detecting high-density materials in cargo containers.

Specifications (preliminary)

1.0 Performance

1.1 X-ray Beam Energy

The nominal peak beam energies are 6 and 9 MeV.

1.2 X-ray Beam Dose Rate

The dose rate is specified at one meter from the target, on the central axis, for one minute (Gy/min-m). The continuous duty un-flattened, central axis dose rate is 1.00 Gy/min-m at 6 and 9 MeV.

1.3 X-ray Field Size

Beam and field size are based on the collimator specified by the customer.

1.4 X-ray Beam Flatness

The minimum vertical 6 MeV dose rate is 62%, and the minimum 9 MeV dose rate is 55% of the central axis dose rate at $\pm 7.5^\circ$ off the central axis.

1.5 X-ray Beam Symmetry

The beam asymmetry does not exceed 5% at $\pm 7.5^\circ$ off the central axis in the vertical direction.

1.6 X-ray Beam Stability

Dose variation within $\pm 15\%$ in first 15 seconds. Use of reference detector recommended.

1.7 X-ray Beam Focal Spot Size

The focal spot size does not exceed 3.5 mm (FWHM) in diameter for both energies.

1.8 Radiographic Quality

The system will demonstrate at least ASTM E 94 2-2T, or equivalent, sensitivity at 6 MeV over a range of 51 mm (2") to 254 mm (10") of steel. The sensitivity is the same for 9 MeV over a range of 76 mm (3.0") to 380 mm (15") of steel. The X-ray beam must be collimated to the object size, and the object must be at least 1 meter from any backscatter material.



X-ray Head

Linatron® K9A High-energy X-ray source

2.0 Equipment Features

2.1 General Arrangement

Horizontal operation

2.2 X-ray Head Orientation

The X-ray head can operate at a $\pm 30^\circ$ pitch and a $\pm 15^\circ$ roll. For vertical operation, please consult factory.

2.3 Leakage Radiation

The leakage radiation specification is 1×10^{-3} fraction of the primary beam, and is measured at 1 meter from the beam centerline at angles outside a 90° forward directed cone. The K9A high-energy photons produce neutron radiation. The neutron production must be considered in plant building design. Special K9A shielding limits the neutron leakage to approximately 1×10^{-3} Rem per X-ray rad in the forward direction from $\pm 90^\circ$ outside the collimator and 1×10^{-4} Rem per X-ray rad in all other directions.

2.4 Cabinet Enclosures

All components in the X-ray head, modulator cabinet, and temperature control unit are contained within grounded metal enclosures. The temperature control unit is rated for outdoor operation.

3.0 Controls

3.1 Control System

The control system uses a programmable logic controller (PLC) to control and monitor all K9A functions. This allows the K9A to easily interface with the customer's external control system.

3.2 Control Console

The standard control console is a touch screen display system. An optional desktop PC control console is available (see section 4.1)

4.0 Optional Equipment

4.1 Desktop PC Control Console

The desktop PC control console provides the same system control as the touch screen console but has a larger viewing screen plus data storage capability. Heat given to room air is 0.5 kW.

4.2 Temperature Control Unit

The Temperature Control Unit keeps the water system operating at the specified temperature. This is a stand-alone closed loop system. The low temperature option provides heating for environments less than -10°C .

5.0 Installation Requirements

5.1 Power Source Description

The system operates from a single 45 kVA power source.

60 Hz Operation

440V 3-phase, 3 wire plus ground (4 wire system), 60 Amp minimum surge per leg, at $\pm 5\%$ voltage regulation is required.

50 Hz Operation

400V 3 phase, 3 wire plus ground and neutral (5 wire system) 65 Amp minimum surge per leg, at $\pm 5\%$ voltage regulation is required.

6.0 Cooling and Ventilation

6.1 Indoor Service

The room temperature for all equipment must be between 5°C (41°F) and 35°C (95°F) with maximum 90% RH (non-condensing).

6.2 Room Ventilation Requirements

The table below lists the approximate heat given to room air from each system component.

Table 1

Unit	Heat Load (kW)
X-ray Head	5.0
Modulator	5.0
Control Console	Negligible
Temp. Control Unit (TCU)	30.0

7.0 Physical Description

7.1 The table below lists the systems component dimensions and weights.

Table 2

Units	Height cm (in)	Width cm (in)	Depth cm (in)	Weight kg (lb)
X-ray Head*	130 (51)	155 (61)	251 (99)	4,309 (9,500)
Console	22 (9)	48 (19)	30 (12)	4 (9)
Modulator	141 (56)	102 (40)	92 (36)	567 (1,250)

* Custom collimators increase head weight and depth.

7.2 Dimensional Drawings (Dimensions in inches)

X-ray Head

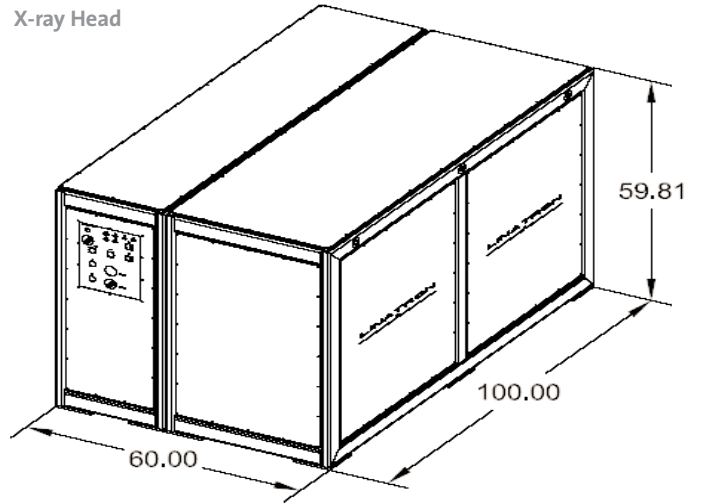

Modulator

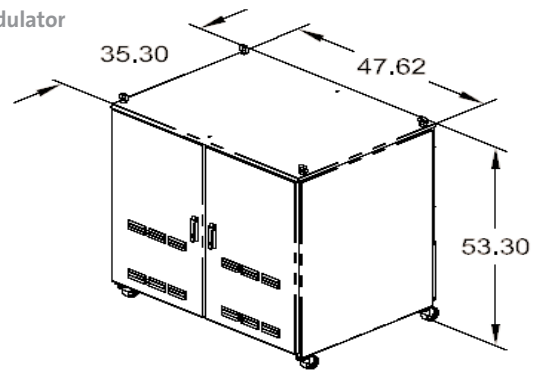

Please provide eps files for drawings

Linatron® K9A High-energy X-ray source

ETL Marking

The Linatron K9A conforms to UL STD 61010A-1 and is certified to CSA 1010.1.

Quality Standard

Varian Security & Inspection Products is registered to ISO 9001:2000 quality management standard by B.S.I.



ISO 9001:2000
FM 80701

Specifications subject to change without notice.

Varian, Varian Medical Systems, and Linatron are registered trademarks, and Linatron-M is a trademark of Varian Medical Systems, Inc. The names of other companies and products mentioned herein are used for identification purposes only and may be trademarks or registered trademarks of their respective owners.



Security & Inspection Products

6883 Spencer Street, Las Vegas, NV 89119
tel: 702.938.4859 www.varian.com/sip
fax: 702.938.4833 linatron@varian.com